

# JET®

## Operating Instructions and Parts Manual 10" Compound Miter Saw Benchtop Series – Model No. JMS-10CMS



**WMH TOOL GROUP, Inc.**  
2420 Vantage Drive  
Elgin, Illinois 60124  
Ph.: 800-274-6848  
[www.wmhtoolgroup.com](http://www.wmhtoolgroup.com)

Part No. M-707100  
Revision A 11/08  
Copyright © 2008 WMH Tool Group, Inc.

# Warranty and Service

WMH Tool Group, Inc., warrants every product it sells. If one of our tools needs service or repair, one of our Authorized Service Centers located throughout the United States can give you quick service. In most cases, any of these WMH Tool Group Authorized Service Centers can authorize warranty repair, assist you in obtaining parts, or perform routine maintenance and major repair on your JET® tools. For the name of an Authorized Service Center in your area call 1-800-274-6848.

## MORE INFORMATION

WMH Tool Group is consistently adding new products to the line. For complete, up-to-date product information, check with your local WMH Tool Group distributor, or visit [jettools.com](http://jettools.com).

## WARRANTY

JET products carry a limited warranty which varies in duration based upon the product (MW stands for Metalworking, WW stands for Woodworking).

<b>90</b> DAY WARRANTY	<b>1</b> YEAR WARRANTY	Body Repair Kits Bottle Jacks Cable Pullers Cold Saws Hoists-Air Hoists-Electric Metal forming Mill/Drills Milling Machines MW Bandsaws MW Drill Presses MW Finishing Equipment MW Lathes MW Precision Vises	<b>2</b> YEAR WARRANTY	Palet Trucks Rigging Equip. Service Jacks Stackers Surface Grinders Tapping Trolleys-Air Trolleys-Electric Web Slings Winches-Electric	<b>3</b> YEAR WARRANTY	WW Benchtop Tools	<b>5</b> YEAR WARRANTY	Beam Clamps Chain Hoist-Manual Lever Hoists Pullers-JCH Models Scissor Lift Tables Screw Jacks Trolleys-Gearred Trolleys-Plain Winches-Manual WW Air Filtration WW Bandsaws WW Buffers	WW Drill Presses WW Dust Collectors WW Dust Filters WW Dust Fittings WW Jointers WW Lathes WW Planers WW Sanders WW Shapers WW Tablesaws	<b>LIFE</b> LIFETIME WARRANTY	Fastening Tools Mechanics Hand Tools Striking Tools Vises (no -precision) Clamps
<i>Warranty reverts to 1 Year Warranty if woodworking (WW) products listed above are used for industrial or educational purposes.</i>											

## WHAT IS COVERED?

This warranty covers any defects in workmanship or materials subject to the exceptions stated below. Cutting tools, abrasives and other consumables are excluded from warranty coverage.

## WHO IS COVERED?

This warranty covers only the initial purchaser of the product.

## WHAT IS THE PERIOD OF COVERAGE?

The general JET warranty lasts for the time period specified in the product literature of each product.

## WHAT IS NOT COVERED?

Three Year, Five Year and Lifetime Warranties do not cover products used for industrial or educational purposes. Products with Three Year, Five Year or Lifetime Warranties that are used for industrial or education purposes revert to a One Year Warranty. This warranty does not cover defects due directly or indirectly to misuse, abuse, negligence or accidents, normal wear-and-tear, improper repair or alterations, or lack of maintenance.

## HOW TO GET SERVICE

The product or part must be returned for examination, postage prepaid, to a location designated by us. For the name of the location nearest you, please call 1-800-274-6848.

You must provide proof of initial purchase date and an explanation of the complaint must accompany the merchandise. If our inspection discloses a defect, we will repair or replace the product, or refund the purchase price, at our option. We will return the repaired product or replacement at our expense unless it is determined by us that there is no defect, or that the defect resulted from causes not within the scope of our warranty in which case we will, at your direction, dispose of or return the product. In the event you choose to have the product returned, you will be responsible for the shipping and handling costs of the return.

## HOW STATE LAW APPLIES

This warranty gives you specific legal rights; you may also have other rights which vary from state to state.

## LIMITATIONS ON THIS WARRANTY

WMH TOOL GROUP LIMITS ALL IMPLIED WARRANTIES TO THE PERIOD OF THE LIMITED WARRANTY FOR EACH PRODUCT. EXCEPT AS STATED HEREIN, ANY IMPLIED WARRANTIES OR MERCHANTABILITY AND FITNESS ARE EXCLUDED. SOME STATES DO NOT ALLOW LIMITATIONS ON HOW LONG THE IMPLIED WARRANTY LASTS, SO THE ABOVE LIMITATION MAY NOT APPLY TO YOU.

WMH TOOL GROUP SHALL IN NO EVENT BE LIABLE FOR DEATH, INJURIES TO PERSONS OR PROPERTY, OR FOR INCIDENTAL, CONTINGENT, SPECIAL, OR CONSEQUENTIAL DAMAGES ARISING FROM THE USE OF OUR PRODUCTS. SOME STATES DO NOT ALLOW THE EXCLUSION OR LIMITATION OF INCIDENTAL OR CONSEQUENTIAL DAMAGES, SO THE ABOVE LIMITATION OR EXCLUSION MAY NOT APPLY TO YOU.

WMH Tool Group sells through distributors only. The specifications in WMH catalogs are given as general information and are not binding. Members of WMH Tool Group reserve the right to effect at any time, without prior notice, those alterations to parts, fittings, and accessory equipment which they may deem necessary for any reason whatsoever. JET® branded products are not sold in Canada by WMH Tool Group.

# Table of Contents

Warranty and Service .....	2
Table of Contents .....	3
Warnings.....	4
Compound Miter Saw Safety .....	6
Introduction .....	7
Specifications.....	7
Cutting Capacity .....	7
Electrical .....	8
Features.....	9
Shipping Contents .....	10
Assembly .....	11
Adjustments .....	14
Operation .....	18
Crown Molding Chart.....	23
Maintenance .....	24
Troubleshooting.....	25
Parts .....	26
Wiring Diagram .....	33

The specifications in this manual are given as general information and are not binding. WMH Tool Group, Inc. reserves the right to effect, at any time and without prior notice, changes or alterations to parts, fittings, and accessory equipment deemed necessary for any reason whatsoever.



# Warnings

1. Read and understand the entire owners' manual before attempting assembly or operation.
2. Read and understand the warnings posted on the machine and in this manual. Failure to comply with all of these warnings may cause serious injury.
3. Replace the warning labels if they become obscured or removed.
4. This saw is designed and intended for use by properly trained and experienced personnel only. If you are not familiar with the proper and safe operation of a compound miter saw, do not use until proper training and knowledge have been obtained.
5. Do not use this saw for other than its intended use. If used for other purposes, WMH Tool Group disclaims any real or implied warranty and holds itself harmless from any injury that may result from that use.
6. Always wear approved safety glasses/face shields while using this miter saw. Everyday eyeglasses only have impact resistant lenses; they are not safety glasses.
7. Before operating this saw, remove tie, rings, watches and other jewelry, and roll sleeves up past the elbows. Remove all loose clothing and confine long hair. Non-slip footwear or anti-skid floor strips are recommended. Do **not** wear gloves.
8. Wear ear protectors (plugs or muffs) during extended periods of operation.
9. Some dust created by power sanding, sawing, grinding, drilling and other construction activities contain chemicals known to cause cancer, birth defects or other reproductive harm. Some examples of these chemicals are:
  - Lead from lead based paint.
  - Crystalline silica from bricks, cement and other masonry products.
  - Arsenic and chromium from chemically treated lumber.Your risk of exposure varies, depending on how often you do this type of work. To reduce your exposure to these chemicals, work in a well-ventilated area and work with approved safety equipment, such as face or dust masks that are specifically designed to filter out microscopic particles.
10. Do not operate this machine while tired or under the influence of drugs, alcohol or any medication.
11. Make certain the switch is in the **OFF** position before connecting the machine to the power supply.
12. Make certain the machine is properly grounded.
13. Make all machine adjustments or maintenance with the machine unplugged from the power source.
14. Remove adjusting keys and wrenches. Form a habit of checking to see that keys and adjusting wrenches are removed from the machine before turning it on.
15. Keep safety guards in place at all times when the machine is in use. If removed for maintenance purposes, use extreme caution and replace the guards immediately.
16. Make sure this machine is firmly secured to the floor or bench before use.
17. Check damaged parts. Before further use of the machine, a guard or other part that is damaged should be carefully checked to determine that it will operate properly and perform its intended function. Check for alignment of moving parts, binding of moving parts, breakage of parts, mounting and any other conditions that may affect its operation. A guard or other part that is damaged should be properly repaired or replaced.
18. Provide for adequate space surrounding work area and non-glare, overhead lighting.
19. Keep the floor around the machine clean and free of scrap material, oil and grease.

# Warnings

20. Don't use in dangerous environment. Don't use power tools in damp or wet locations, or expose them to rain. Keep work area well lighted.
21. Keep visitors a safe distance from the work area. **Keep children away.**
22. Make your workshop child proof with padlocks, master switches or by removing starter keys.
23. Give your work undivided attention. Looking around, carrying on a conversation and "horse-play" are careless acts that can result in serious injury.
24. Maintain a balanced stance at all times so that you do not fall or lean against the blade or other moving parts. Do not overreach or use excessive force to perform any machine operation.
25. Use the right tool at the correct speed and feed rate. Do not force a tool or attachment to do a job for which it was not designed. The right tool will do the job better and safer.
26. Use recommended accessories; improper accessories may be hazardous.
27. Maintain tools with care. Keep saw blades sharp and clean for the best and safest performance. Follow instructions for lubricating and changing accessories.
28. Disconnect tools before servicing and when changing accessories such as blades.
29. Make sure the work piece is securely attached or clamped to the table.
30. Turn off the machine before cleaning. Use a brush or compressed air to remove chips or debris — do not use your hands.
31. Do not stand on the machine. Serious injury could occur if the machine tips over.
32. Never leave the machine running unattended. Turn the power off and do not leave the machine until it comes to a complete stop.
33. Remove loose items and unnecessary work pieces from the area before starting the machine.

## **Familiarize yourself with the following safety notices used in this manual:**

**CAUTION** This means that if precautions are not heeded, it may result in minor injury and/or possible machine damage.

**WARNING** This means that if precautions are not heeded, it may result in serious injury or possibly even death.

# Compound Miter Saw Safety

Specific safety instructions for this compound miter saw

1. Do not operate the miter saw until it is completely assembled and installed according to these instructions.
2. If you are not thoroughly familiar with the operation of miter saws, seek guidance from your supervisor, instructor or other qualified person.
3. Always hold the work firmly against the fence and table.
4. Do not perform any operation free hand (use clamp wherever possible).
5. Keep hands out of the path of the saw blade. If the workpiece you are cutting would cause your hands to be within 6-3/4 in. of the saw blade, the workpiece should be clamped in place before making the cut.
6. Be sure the blade is sharp, runs freely and is free of vibration.
7. Allow the motor to come up to full speed before starting a cut.
8. Keep the motor air slots clean and free of chips or dust.
9. Always make sure all handles are tight before cutting, even if the table is positioned in one of the positive stops.
10. Be sure both the blade and the collar are clean and the arbor bolt is tightened securely.
11. Use only blade collars specified for your saw.
12. Never use blades larger in diameter than 10 inches.
13. Never apply lubricants to the blade when it is running.
14. Always check the blade for cracks or damage before operation. Replace a cracked or damaged blade immediately.
15. Never use blades recommended for operation at less than 4800 RPM.
16. Always keep the blade guards in place and use at all times.
17. Never reach around the saw blade.
18. Make sure the blade is not contacting the workpiece before the switch is turned ON.
19. Important: After completing the cut, release the trigger and wait for the blade to stop before returning the saw to the raised position.
20. Make sure the blade has come to a complete stop before removing or securing the workpiece, changing the workpiece angle or changing the angle of the blade.
21. Never cut metals or masonry products with this tool. This miter saw is designed for use on wood and wood-like products.
22. Never cut small pieces. If the workpiece being cut would cause your hand or fingers to be within 6-3/4 in. of the saw blade the workpiece is too small.
23. Provide adequate support to the sides of the saw table for long work pieces.
24. Never use the miter saw in an area with flammable liquids or gases.
25. Never use solvents to clean plastic parts. Solvents could possibly dissolve or otherwise damage the material.
26. Shut off the power before servicing or adjusting the tool.
27. Disconnect the saw from the power source and clean the machine when finished using.
28. Make sure the work area is clean before leaving the machine.
29. Should any part of your miter saw be missing, damaged, or fail in any way, or any electrical component fail to perform properly, lock the switch and remove the plug from the power supply outlet. Replace missing, damaged, or failed parts before resuming operation.

## Introduction

This manual is provided by WMH Tool Group covering the safe operation and maintenance procedures for the JET Model JMS-10CMS *Compound Miter Saw* with laser. This manual contains instructions on installation, safety precautions, general operating procedures, maintenance instructions and parts breakdown. This machine has been designed and constructed to provide years of trouble free operation if used in accordance with instructions set forth in this manual. If there are any questions or comments, please contact either your local supplier or WMH Tool Group. WMH Tool Group can also be reached at our web site: [www.wmhtoolgroup.com](http://www.wmhtoolgroup.com).

## Specifications

Model Number.....JMS-10CMS  
 Stock Number ..... 707100  
 Motor ..... 120V, 60Hz, 15A  
 No Load Speed (Arbor)..... 4800RPM  
 Motor Arbor Shaft Size..... 5/8"  
 Blade ..... 10", 40T, carbide tipped  
 Blade Arbor Size ..... 5/8"  
 Net Weight..... 33.3 lb.

The above specifications were current at the time this manual was published, but because of our policy of continuous improvement, WHM Tool Group reserves the right to change specifications at any time and without prior notice, without incurring obligations.

## Cutting Capacity

Cut Type	Miter Angle	Bevel Angle	Cutting Capacity	Cutting Capacity with 3/4" Auxiliary Fence
Cross Cut	0°	0°	2-5/8" x 5-1/2"	3-1/2" x 3-1/2"
Miter	45° Right & Left	0°	2-5/8" x 3-1/2"	3-1/2" x 2"
Bevel	0°	45° Left	1-1/2" x 5-1/2"	2" x 3-1/2"
Compound Cut	45° Right & Left	45° Left	1-1/2" x 3-1/2"	2" x 2"
Vertical Capacity (Base Board)	--	--	4"	

**⚠WARNING** Read and understand the entire contents of this manual before attempting assembly or operation! Failure to comply may cause serious injury!

## Electrical

### Power Supply and Motor Specifications

The AC motor used in this saw is a universal, nonreversible type (see *Motor* in the *Specifications* section on page 7).

**⚠WARNING** To avoid electrical hazards, fire hazards, or damage to the machine, use proper circuit protection. Your saw is wired at the factory for 120V operation. Connect to a 120V, 15 Amp circuit and use a 15 amp time delay fuse or circuit breaker. If power cord is worn or cut, or damaged in any way, have it replaced immediately to avoid shock or fire.

### Electrical Requirements

This machine is double insulated to provide a double thickness of insulation between the user and the machine's electrical system. All exposed metal parts are isolated from the internal metal motor components with protective insulation.

This saw has a plug that looks like the one shown in Figure A.

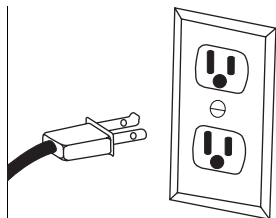

Figure A

To reduce the risk of electrical shock, this saw has a polarized plug (one blade is wider than the other). This plug will fit in a polarized outlet only one way; if the plug does not fit fully in the outlet, reverse the plug. If it still does not fit, contact a qualified electrician to install the proper outlet. Do not change the plug in any way.

Double insulation does not take the place of normal safety precautions when operating this tool.

To avoid electrocution:

1. Use only identical replacement parts when servicing a tool with double insulation. Servicing should be performed by a qualified technician.
2. Do not use power tools in wet or damp locations or expose them to rain or snow.

## Extension Cords

Make sure your extension cord is in good condition. When using an extension cord, be sure to use one heavy enough to carry the current your machine will draw. An undersized cord will cause a drop in the line voltage resulting in power loss and overheating. The table below shows the correct size to use depending on the cord length and nameplate ampere rating. If in doubt, use the next heavier gauge. Remember, the smaller the gauge number, the heavier the cord.

Cord Length	AWG
0 – 25ft	16
5 – 50ft	14

**Important:** Make certain the receptacle in question is properly grounded. If you are not sure, have a registered electrician check the receptacle.



# Features

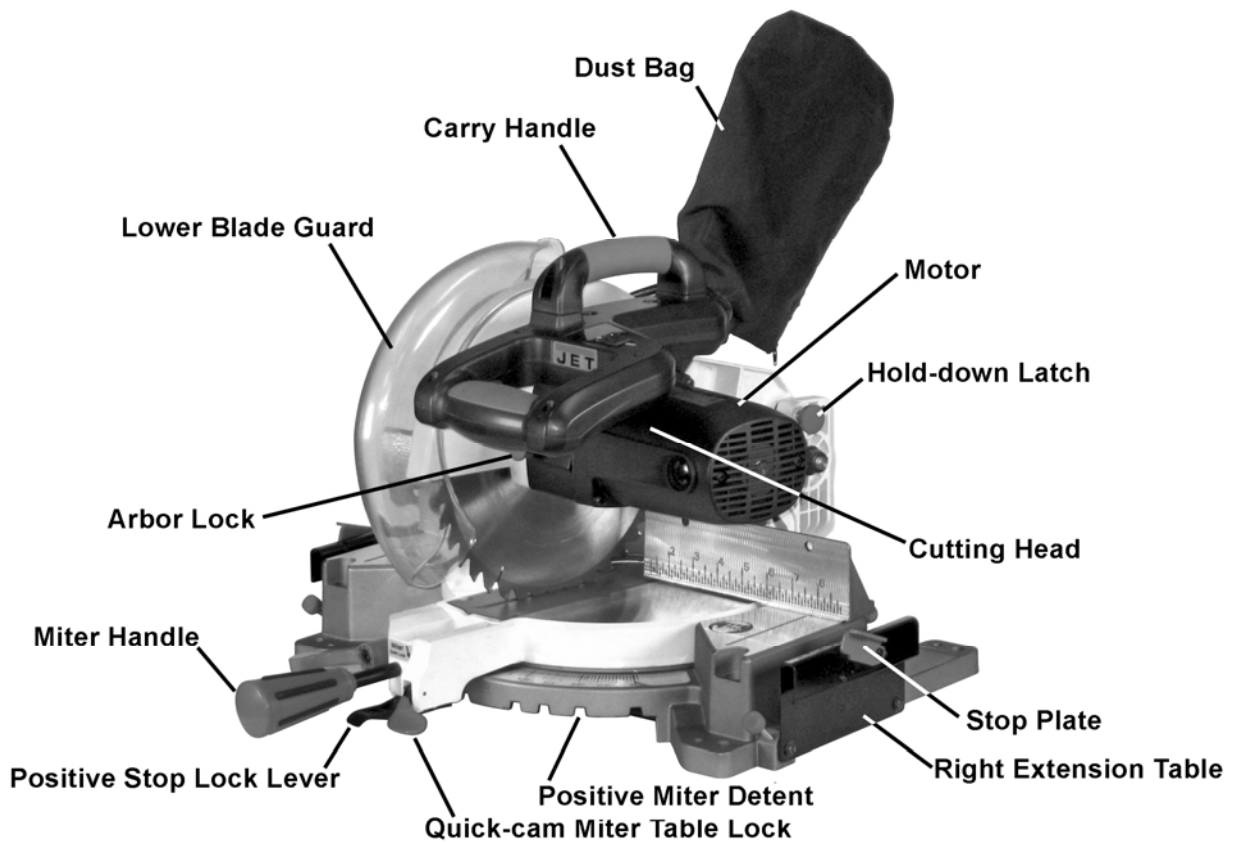
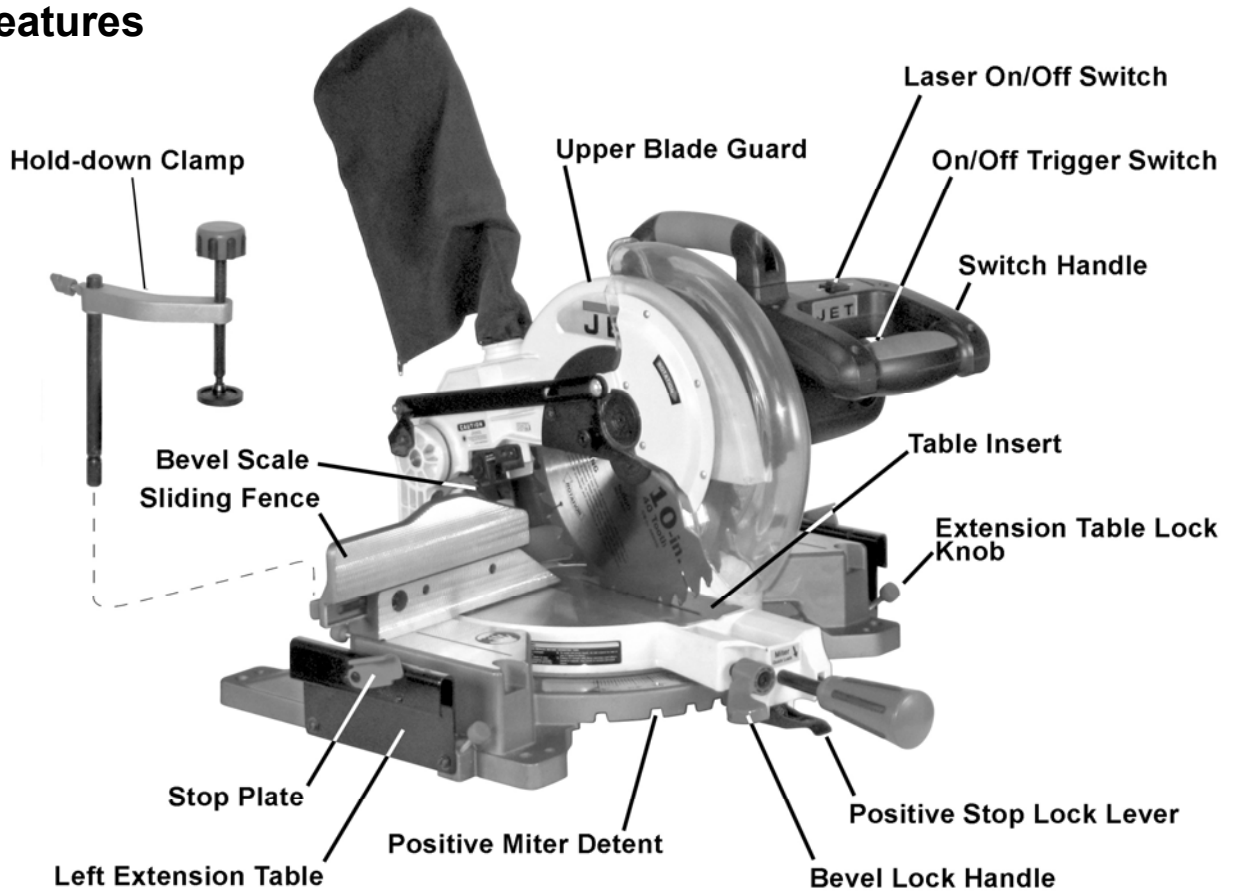

# Shipping Contents

## Unpacking

1. Remove the contents from the shipping container.
2. Compare the contents of the shipping container with the list found below. Make certain that all items are accounted for before discarding any packing material. Report any shortages or damage to your JET distributor.

## Contents of the Shipping Container

- A Miter Saw (1)
- B Hold-down Clamp (1)
- C Miter Handle (1)
- E Lock Knob (2)
- F Dust Bag (1)
- G Extension Table (2)
- H Screw (2)
- Owner's Manual (1)
- Warranty Registration Card

## Tools Supplied for Assembly

- D Blade Wrench

## Tools not included

- Adjustable Wrench
- 6mm Hex Wrench
- Crosspoint Screwdriver
- Combination Wrench

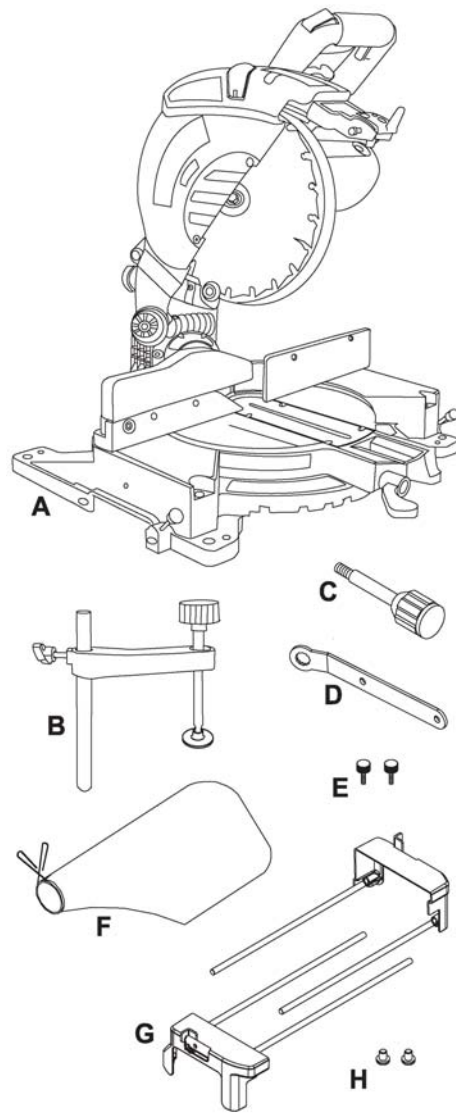

Contents of Shipping Container

**⚠ WARNING** Read and understand all assembly instructions before attempting assembly! Failure to comply may cause serious injury!

# Assembly

## Releasing the Cutting Head

**⚠WARNING** When not in use, lock the cutting head in the down position. Failure to comply can cause serious injury or damage equipment.

Refer to Figure 1.

### Unlocking

1. Push down on the *switch handle* (A).
2. Pull out the *hold-down latch* (B).
3. Raise the cutting head to the up position.

### Locking

**Note:** When not in use, lock the cutting head in the down position.

1. Push the cutting head down.
2. Press the *hold-down latch* (B) in to lock.

**Important:** Always use the carrying handles when lifting or moving to avoid damage to the machine.

## Installing the Extension Table

Referring to figure 2:

1. Loosen the extension table *lock knob* (E).
2. Place the extension *mounting tube* (D) into the two holes provided in the miter saw base.
3. From underneath the saw, insert one *screw* (B) into the mounting tube *hole* (4) and tighten.
4. Slide the extension table to desired position and tighten the extension table *lock knob* (E).
5. Install the right extension table in the same manner.

## Installing the Miter Handle

Thread the *miter handle* (F, Fig. 2) into the hole located at the front of the miter table.

## Installing the Dust Bag

Referring to Figure 3:

1. Squeeze the metal collar wings of the *dust bag* (A).
2. Place the dust bag neck opening around the *exhaust port* (B), and release the collar wings.

To empty the dust bag, remove from exhaust port, open zipper on underside of bag and empty into waste container.

**Note:** Check and empty bag frequently. Do not wait for it to get full.

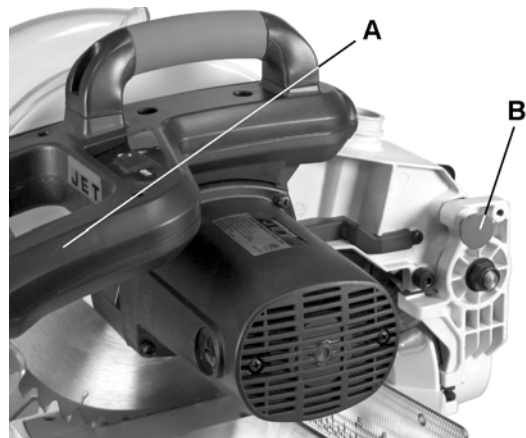

Figure 1

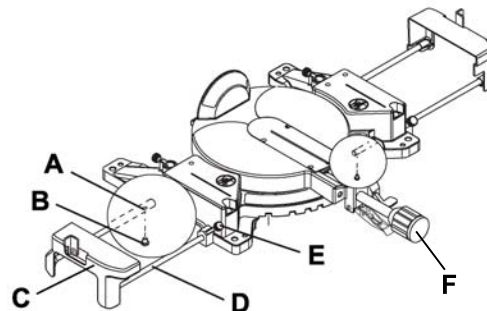

Figure 2

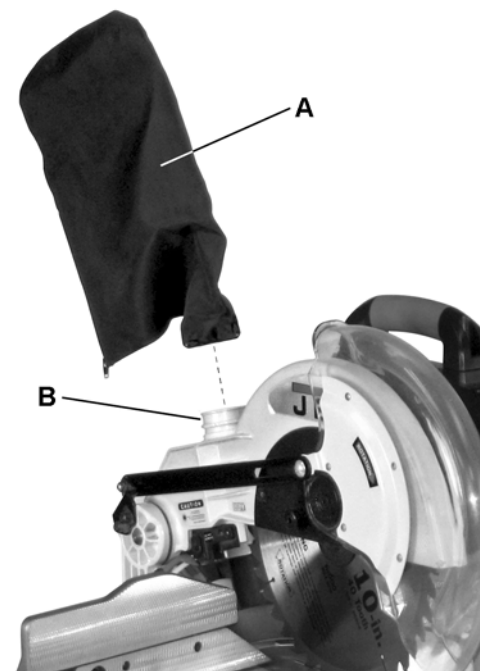

Figure 3

## Installing the Safety Hold-down Clamp

1. Place the *hold-down clamp assembly* (A, Fig. 4) in a mounting hole located behind the right or left (shown) *fence* (C).
2. Thread the *hold-down clamp knob* (B) into the hole located at the rear of the saw base.
3. Tighten the *hold-down clamp knob* (B).

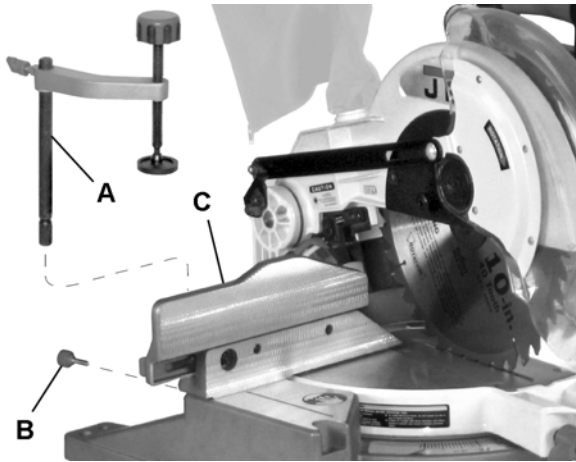

Figure 4

## Table Inserts

**▲WARNING** Always unplug the saw to avoid accidental starting. Failure to comply may cause serious injury!

- ❑ Remove table insert to remove all small pieces of debris from the table cavity before performing any cuts.
- ❑ Be sure to reattach the table insert prior to performing a cutting operation.

**▲WARNING** Do not start the saw without checking for interference between the blade and table insert.

Damage could result to the blade, table insert or turntable if blade strike occurs during the cutting operation.

### To remove:

1. Loosen and remove four screws on the *table insert* (see *Features* on page 9) with a cross-point screwdriver
2. Remove the insert.

### To install:

1. Reposition the table insert.
2. Install the four screws and tighten.

Check for blade clearance by moving the slide carriage through the full motion of the blade in the table slot.

## Mounting the Saw

Observe the following safety measures to avoid injury from unexpected saw movement:

- Disconnect the power cord and lock the cutting head in the lower position.

### When lifting:

- Use the carry handle.
- Bend at the knees, not from the back.
- Clamp or bolt the saw on a level work surface.

### For stationary use:

Select a location for the saw, such as the top of a workbench, making sure to provide sufficient room for handling the workpiece. Secure the saw to the bench.

Mounting hardware is not included and must be purchased separately.

### For portable use:

Place the saw on a 3/4 in. thick piece of plywood and bolt the base securely to the plywood using the mounting holes on the base. Mounting hardware is not included and must be purchased separately.

Use C-clamps to clamp this mounting board to a stable work surface at the worksite.

## Removing the Blade

**▲WARNING** Disconnect power and make sure the switch is in the OFF position to avoid accidental starts. Failure to comply may cause serious injury!

Referring to Figure 5:

1. Unplug the saw from the outlet.
2. Raise the miter saw to the upright position.
3. Raise the lower *blade guard* (A) to the uppermost position.
4. While holding the lower blade guard, loosen the *cover plate screw* (B) with a cross-point screwdriver.
5. Rotate the *cover plate* (D) to expose the *arbor bolt* (C).
6. Place the *blade wrench* over the *arbor bolt* (C).
7. Locate the *arbor lock* (F) on the motor, below the *switch handle* (E).
8. Press the arbor lock, holding it in firmly while turning the blade clockwise. The arbor lock will then engage and lock the arbor. Continue to hold the arbor lock, while turning the wrench clockwise to loosen the arbor bolt.

- Remove the *arbor bolt* (H), *arbor collar* (J), and *blade* (K). Do not remove the inner blade collar.

**Note:** Pay attention to the pieces removed, noting their position and direction they face. Wipe the blade collars clean of any sawdust before installing a new blade.

## Installing Blade

**Important:** This machine requires a 10-inch diameter blade.

Unplug the miter saw before changing and/or installing the blade.

Referring to Figure 5:

- Install a 10-in. blade, making sure the rotation arrow on the blade matches the clockwise rotation arrow on the upper guard and the blade teeth are pointing downward.
- Place the *arbor collar* (J) against the blade and on the *arbor* (L). Thread the *arbor bolt* (H) on the arbor in a counterclockwise direction.

**Important:** Make sure that the flat edge inside opening of the *arbor collar* (J) is aligned with the flat edge on the *arbor shaft* (L). Also, the flat-side of the *arbor collar* (J) must be placed against the *blade* (K).

- Place the blade wrench on the *arbor bolt* (H).
- Press the *arbor lock* (F), holding it in firmly while turning the blade counterclockwise (opposite the cutting direction of the blade). When it engages, continue to press the *arbor lock* (F) in, while tightening the *arbor bolt* (H) securely.
- Rotate the *cover plate* (D) back to its original position until the slot in the cover plate engages with the *cover plate screw* (B). While holding the *lower blade guard* (A) up as shown, tighten the *screw* (B) with a cross-point screwdriver.

The cover plate keeps the arbor bolt from falling out if it accidentally loosens, and helps prevent the spinning blade from coming off the saw.

- Lower the *blade guard* (A) and verify that the operation of the guard does not bind or stick.
- Turn the blade to disengage the *arbor lock* (F); then verify that the blade will spin freely.

**⚠ WARNING** Never use the saw without the cover plate secure in place. Failure to comply may cause serious injury!

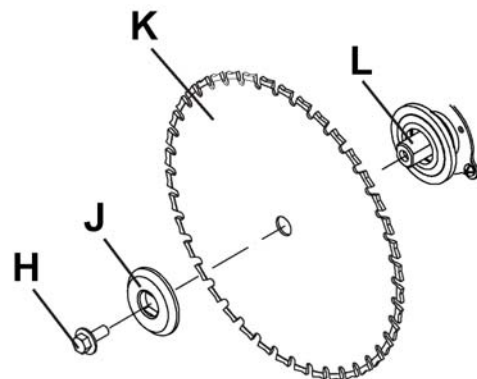
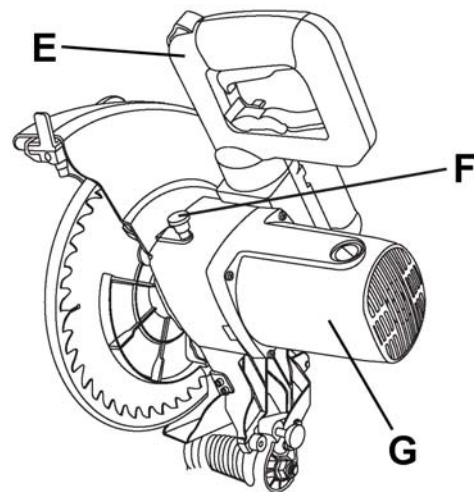
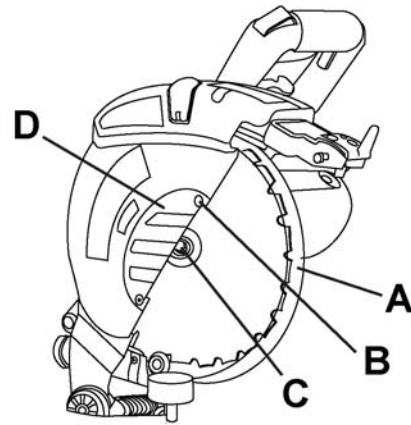

Figure 5

**⚠ WARNING** Verify that the collars are clean and properly installed. Lower the blade into the table and verify that it does not come in contact with the metal base or the turn table. Failure to comply may cause serious injury!

# Adjustments

**⚠WARNING** Before attempting any adjustments, make sure the trigger is released and remove the power cord from the power source to avoid injury from unexpected starting or electrical shock. Failure to comply may cause serious injury!

**Note:** Your miter saw was adjusted at the factory. However, during shipment slight misalignment may have occurred. Check the following settings and adjust if necessary prior to using this miter saw.

## Bevel Stop Adjustments

**⚠WARNING** To avoid injury from unexpected starting or electrical shock, make sure the trigger is released and remove the power cord from the power source.

### 90°(0°) Bevel Adjustment

1. Set the miter angle to 0° (see *Miter Angle* on page 15).

**Note:** A bevel angle of 0° corresponds to a blade-to-miter-table angle of 90°.

2. Turn the *bevel lock handle* (A, Fig. 6) clockwise to loosen and tilt the cutting arm to the 0° bevel angle. Turn the *bevel lock handle* (A) counterclockwise to tighten.
3. Place a combination square on the miter table with the rule against the table and heel of the square against the saw blade.

If the blade is not 90° to the miter table:

4. To adjust, tilt the cutting arm to 45°, loosen the *lock nut* (B, Fig. 7) and turn the *stop bolt* (A,) in or out accordingly.
5. Tilt the cutting arm back to the right and recheck alignment.
6. Repeat steps 1–4 if necessary until the blade is 90° to the table, then tighten the *lock nut* (B, Fig. 7) to secure the *stop bolt* (A, Fig. 7).

### Bevel Scale Indicators

1. Set the blade to be exactly 90°(0°) to the table.
2. With cross-point screwdriver, loosen two *bevel indicator screws* (B, D, Fig. 8).
3. Adjust *bevel indicators* (A, E, Fig. 8) to the “0” marks (C, F, Fig. 8) on the bevel scale and retighten the screws (B, D).

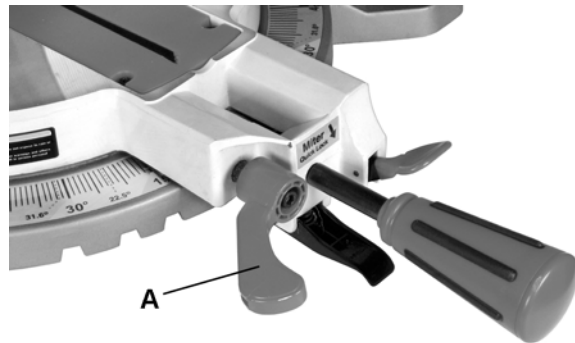

Figure 6

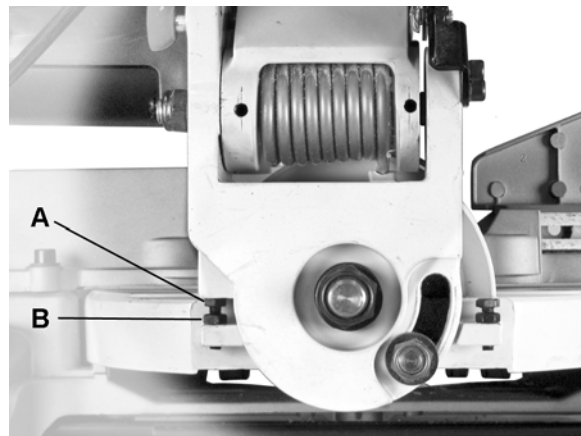

Figure 7

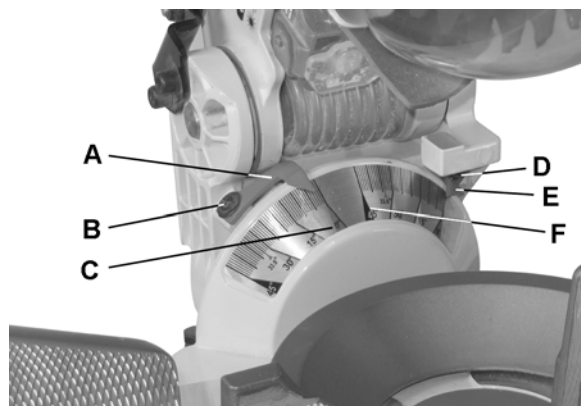

Figure 8

### 45° Left Bevel Positive Stop Adjustment

1. Set the miter angle to 0° (*Miter Angle* - page 15) and fully extend the sliding fence (*Sliding Fence* - page 19) completely to the left.
2. Loosen the *bevel lock handle* (A, Fig. 6) and tilt the cutting arm completely to the left.
3. Using a combination square, check to see if the blade is 45° to the table.

If the blade is not 45° to the miter table:

4. To adjust, tilt the cutting arm to zero degrees, loosen the *lock nut* (B, Fig. 9) and turn the *stop bolt* (A, Fig. 9) in or out accordingly.
5. Tilt the cutting arm back to the left and recheck alignment.
6. Repeat steps 1–4 if necessary until the blade is 45° to the table, then tighten the *lock nut* (B, Fig. 9) to secure the *stop bolt* (A, Fig. 9).

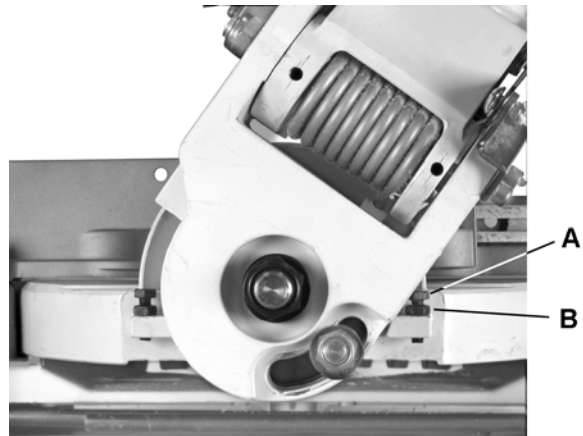

Figure 9

### Miter Angle

The compound miter saw scale can be easily read, showing miter angles from 0° to 45° to the left, and 0° to 45° to the right. The miter saw table has nine of the most common angle settings with positive stops at 0°, 15°, 22.5°, 31.6°, and 45°. These positive stops position the blade at the desired angle quickly and accurately.

Follow the process below for quickest and most accurate adjustments.

Referring to Figure 10:

1. Lift up on the quick-cam *miter table lock* (B) to unlock the table.
2. Lift up on the *positive stop locking lever* (D) and move the turntable with *handle* (C) to align the *indicator* (E) to the desired degree measurement.
3. Lock the table into position by pressing down on the quick-cam *miter table lock* (B).

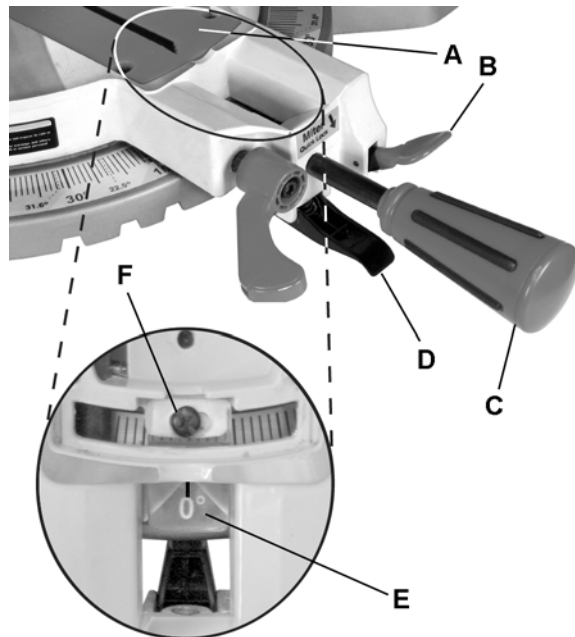

Figure 10

### Miter Scale Indicator Adjustment

1. Move the table to the 0° positive stop.
2. Remove the *table insert* (A).
3. Loosen the *screw* (F) that secures the indicator (E).
4. Adjust the *indicator* (E) to the 0° mark and retighten screw (F).
5. Replace the *table insert* (A).

## Adjusting Fence Squareness

Referring to Figure 11:

1. Loosen two *fence locking screws* (C).  
**Note:** One locking screw is located on each fence.
2. Lower the cutting arm and lock in position.
3. Using a *square* (B), lay the heel of the square against the *blade* (D) and the ruler against the *fence* (A).
4. Adjust the fence 90° to the blade and tighten the two *fence locking screws* (C).

**CAUTION** If the saw has not been used recently, recheck blade squareness to the fence and readjust if needed.

5. After fence has been aligned, using a scrap piece of wood, make a cut at 90° then check squareness on the piece. Readjust if necessary.

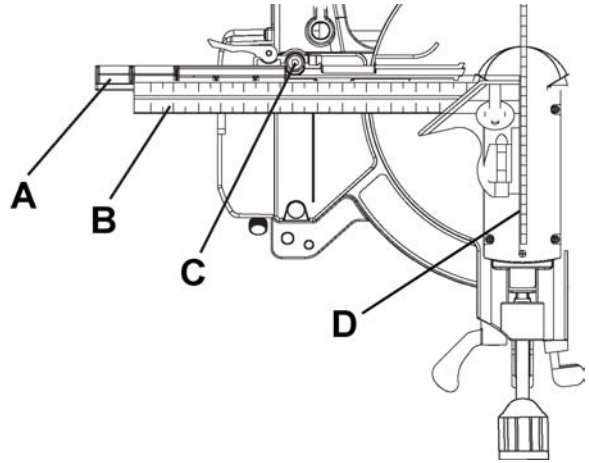

Figure 11

## Positive Stop Miter Angle Adjustment

Referring to Figure 12:

1. Unlock the miter table by lifting up on the quick-cam *miter table lock* (A).
2. Raise the *positive stop locking lever* (C) up; at the same time grasp the *miter handle* (B) and rotate the miter table left or right to the desired angle.
3. Release the *positive stop locking lever* (C) and set the miter at the desired angle making sure the lever snaps into place.

**Note:** There are nine positive stops into which the lever will lock.

4. After the angle is selected, press down on the quick-cam *miter table lock* (A).

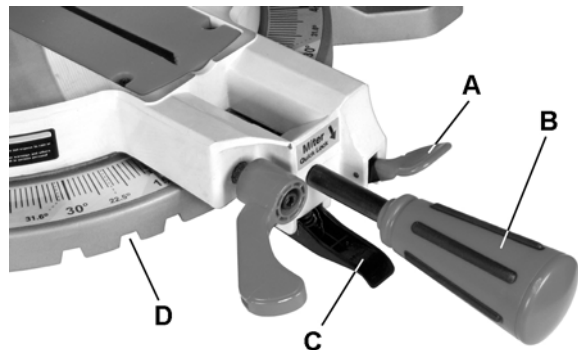

Figure 12

## Quick-cam Miter Table Lock Operation

If a miter angle required is not one of nine positive stops, the miter table can be locked at any angle between these positive stops by using the quick-cam miter table lock.

Referring to Figure 12:

1. Unlock the miter table by lifting up on the quick-cam *miter table lock* (A).
2. Raise the *positive stop locking lever* (C) up; at the same time grasp the *miter handle* (B) and rotate the miter table left or right to the desired angle.

3. Release the positive stop locking lever (C).

4. Press down on the quick-cam *miter table lock* (A) until it locks the miter table in place.

**Note:** The quick-cam miter table lock should lock the table and prevent it from moving. If adjustment is needed, see *Quick-cam Miter Table Lock Adjustment* on following page.



## Quick-cam Miter Table Lock Adjustment Laser Beam

Referring to Figure 13:

1. Place the quick-cam *miter lock* (A) in the down position to lock.
2. Loosen the *lock nut* (D) with a 13mm wrench, then turn the stop nut (E) to extend the locking arm against the base of the miter saw.
3. Test the quick-cam *miter lock* (C) to verify that it locks the table securely into position.
4. Tighten the *lock nut* (D) to lock the miter locking mechanism into place.

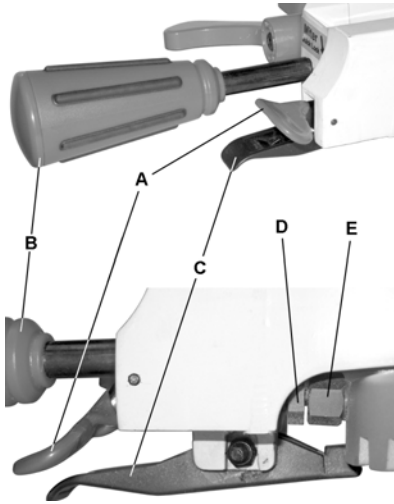

Figure 13

### Cutting Arm Pivot Adjustment

The raising and lowering of the cutting arm should be free of side-to-side play for accurate miter cuts. It should be tight enough to prevent side-to-side movement while still allowing the arm to move freely up and down when cutting.

Referring to Figure 14:

If the *cutting arm* (A) is too loose, tighten by turning the *cutting arm adjusting nut* (B) clockwise with a 19 mm wrench to tighten.

If cutting arm travel is too tight, turn the cutting arm adjusting nut counterclockwise.

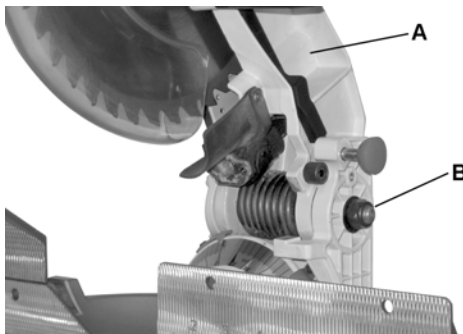
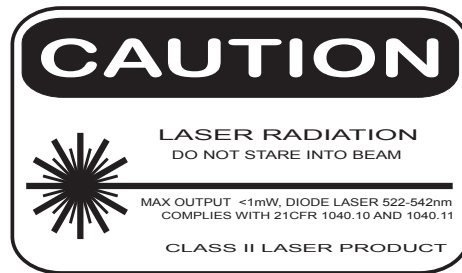

Figure 14

The laser is turned on with a switch located on the saw handle (C, Fig. 15). When left on indefinitely, a sensor will turn the laser off after 20 minutes. The switch must be reset (turned off for two seconds, then on again) to restart.

The laser has no adjustments and should not require adjustment. If adjustment should become necessary, take the miter saw to an approved service center.

- **Laser radiation. Avoid direct eye exposure. Always un-plug miter saw from power source before making any adjustments.**
- **Laser Warning Label: Max output <1mW DIODE LASER: 522-542nm, Complies with 21CFR 1040.10 and 1040.11.**



**CAUTION** Use of controls or adjustments or performance of procedures other than those specified in this manual may result in hazardous radiation exposure.

**CAUTION** The use of optical instruments with this product will increase eye hazard.

- **Do not attempt to repair or disassemble the laser. If unqualified persons attempt to repair this laser product, serious injury may result. Any repair required on this laser product should be performed by authorized service center personnel.**

## Operation

**⚠WARNING** Before attempting any operation with your miter saw, make sure that you have read and thoroughly understand the warnings contained on pages 4-5 and the *Compound Miter Saw Safety* section on page 6. Failure to comply may result in serious injury!

### Starting a cut

1. Place hands at least 6-3/4 in. away from the path of the blade.
2. Hold workpiece firmly against the fence to prevent movement toward the blade.
3. Bring the saw blade down to the workpiece to see the cutting path of the blade.
4. Squeeze the *trigger switch* (A, Fig. 15) to start saw.
5. Lower blade into workpiece with a firm downward motion.

### Finishing a cut

1. Hold the cutting arm in the down position.
2. Release trigger switch (A, Fig. 15) and wait for all moving parts to stop before moving your hands and raising the cutting arm.
3. If the blade does not stop within 10 seconds, unplug the saw and follow the instructions in the *Troubleshooting* section.

### Jammed Material

If material becomes jammed:

1. Release trigger switch.
2. Wait for all moving parts to stop.
3. Unplug the miter saw.

### To Turn the Saw On

Depress the trigger switch (A, Fig. 15).

**Note:** Make the On/Off switch child-proof by inserting a padlock through the hole (B, Fig. 15) in the trigger switch.

The miter saw is equipped with an automatic blade brake. When the trigger switch is released, the electric blade brake will stop the blade within approximately 10 seconds.

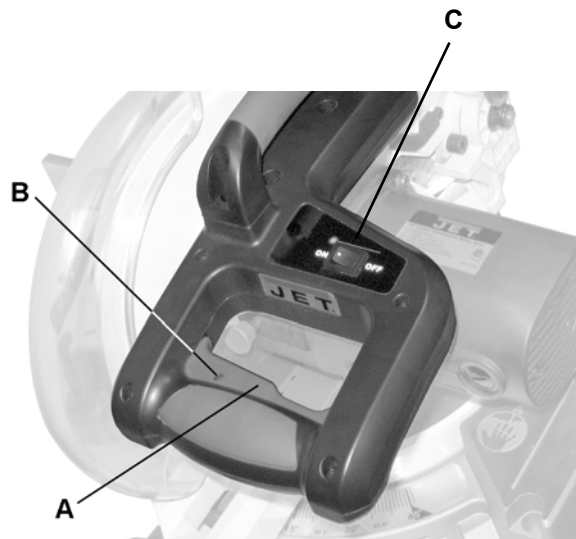

Figure 15

## Sliding Fence

**⚠WARNING** The sliding fence must be extended to the left or right when making bevel cuts. Failure to comply may cause serious injury!

Failure to extend the sliding fence will not allow enough space for the blade to pass through. This could result in serious injury. At extreme miter or bevel angles the saw blade may also contact the fence resulting in damage to equipment as well as personal injury.

To adjust the sliding fence (refer to Figure 16):

1. Unlock the *fence cam locking lever* (A) (shown locked in Figure 16) by pushing it toward the rear of the machine.
2. Extend the *fence* (B) by sliding it out (C) to ensure that the blade will clear the fence for degree of the bevel cut selected. Lock the *fence cam locking lever* (A) as shown.

**Note:** Secure the sliding fence in position closest to the saw blade when transporting the saw.

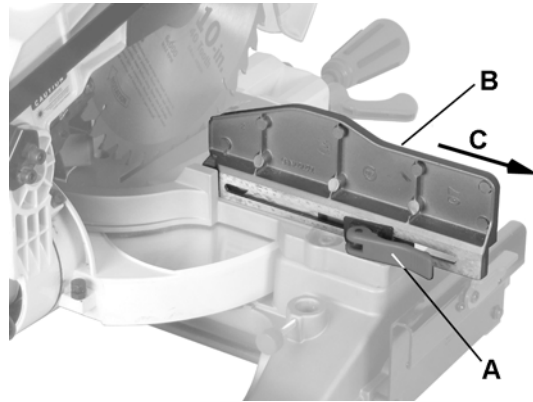

Figure 16

## Miter Cut

Referring to Figure 17:

The sliding compound miter saw has nine positive miter stop detents (A) located on the saw base. The stops represent the following miter cut angles: 0, 15, 22.5, 31.6 and 45 degrees left and right. To make a miter cut:

1. Unlock the miter table by lifting up on the quick-cam *miter table lock* (E).
2. Raise the *positive stop locking lever* (C) up, at the same time grasp the *miter handle* (D) and rotate the miter table left or right to the desired angle.
3. Release the *positive stop locking lever* (C), making sure the lever snaps into place at one of the miter stop detents (A).

**Note:** The miter can be set for any angle between 0° and 45° left and right. However, the lever will only lock into place at one of the nine positive stops indicated above.

Once the desired miter angle is achieved:

4. Press down on the quick cam *miter table lock* (E) to secure the table into position.

If the miter angle desired is *not* one of the nine positive stops noted above:

5. Simply lock the table at the desired angle by pressing down on the quick-cam *miter table lock* (E).

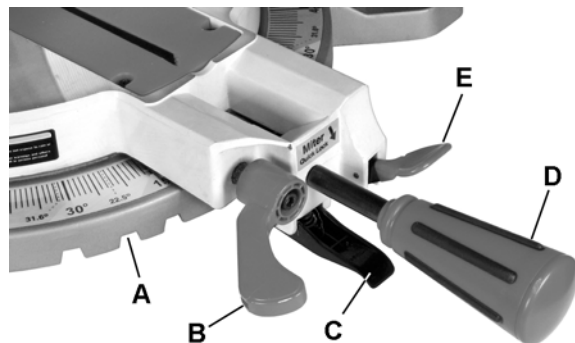

Figure 17

## Bevel Cut

**⚠WARNING** The sliding fence must be extended to the left when making bevel cuts. Failure to comply may cause serious injury!

Failure to extend the sliding fence will not allow enough space for the blade to pass through. This could result in serious injury. At extreme miter or bevel angles the saw blade may also contact the fence resulting in damage to equipment as well as personal injury.

Referring to Figure 18:

1. Loosen the bevel lock handle (B).
2. Tilt the cutting head to the desired level ranging from 0° for a straight cut to a 45° left bevel as displayed on the *bevel scale* (F).
3. Tighten the *bevel lock handle* (B) by pushing down to lock the cutting head in position.

## Compound Cuts

Referring to Figure 18:

### Setting the bevel angle

1. Extend the *fence* (G) by sliding it out to the required location (see *Sliding Fence* on page 19).
2. Loosen the bevel lock handle (B).
3. Set the desired bevel angle; then lock the *bevel lock handle* (B).

### Setting the miter angle

4. Unlock the miter table by lifting up on the quick-cam *miter table lock* (E).
5. Raise the *positive stop locking lever* (C) up, at the same time grasp the *miter handle* (D) and rotate the miter table left or right to the desired angle.
6. Release the positive stop locking lever (C).
7. Lock the miter table by pressing down on the quick-cam *miter table lock* (E).

## Cutting Bowed Material

**⚠WARNING** Always unplug the saw when removing small pieces of debris. Failure to comply may cause serious injury!

Referring to Figure 19:

1. Position a curved *workpiece* (A) against the *fence* (B).
2. Secure the curved workpiece with a *clamping device* (C).

Cutting a curved workpiece without the support of the fence and clamping device could result in personal injury.

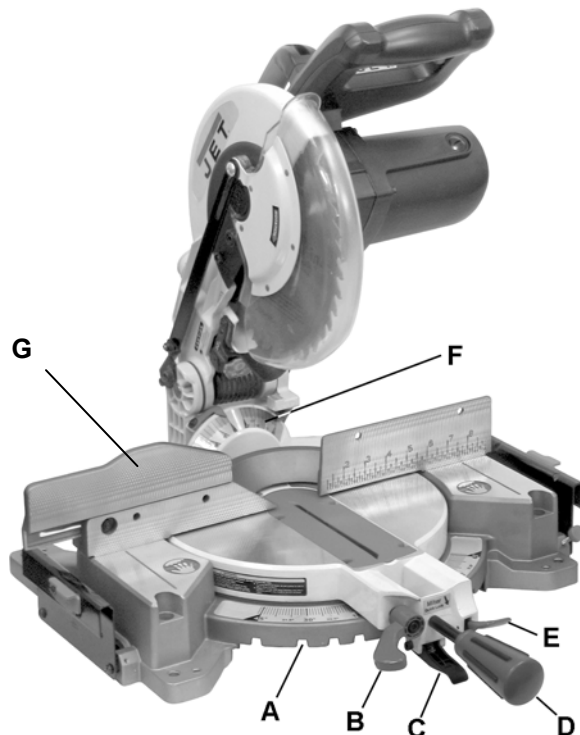

Figure 18

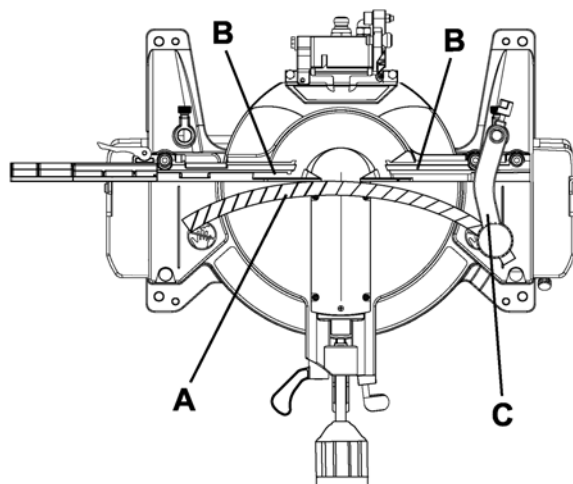

Figure 19

## Repetitive Cutting

**Note:** Long workpieces need extension table support.

Referring to Figure 20:

Loosen the *knob* (E) then slide the *extension wing* (D) to desired position and tighten the knob.

The *stop plate* (C) is designed for use during repetitive cutting. Simply rotate the *stop plate* (C) to vertical position.

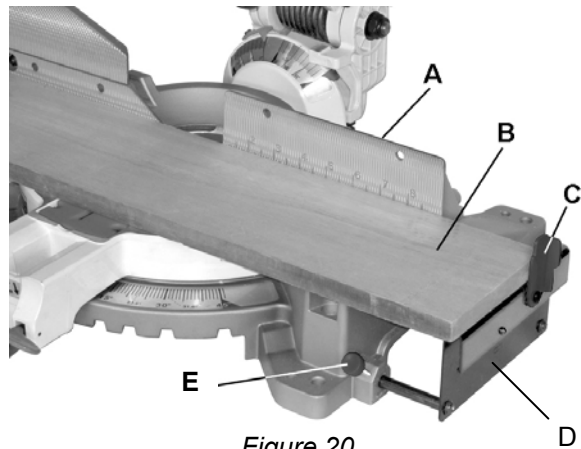

Figure 20

## Auxiliary Wood Fence

Referring to Figure 21:

When making repetitive cuts that produce cut-off pieces of one inch or less, it is possible for the saw blade to catch the cut-off piece and throw it out of the saw or into the blade guard and housing, possibly causing damage or injury. To minimize this, construct an *auxiliary wood fence* (A) to be mounted to your saw which will provide additional depth of cut. Mounting holes are provided on the saw fence (B) for this purpose.

1. Construct the *auxiliary wood fence* (A) of a single, straight piece of wood approximately 3/4 in. thick by 1-1/2 in. high by 22 in. long.
2. Attach the *wood fence* (A) securely to the saw fence (B)
3. Make a full depth cut to create a *blade slot* (C).

Check for interference between the wood fence and the lower blade guard.

4. Make adjustment if necessary.

**Note:** Adding a 3/4" thick auxiliary wood fence will also add cutting capacity (see *Cutting Capacity* on page 7).

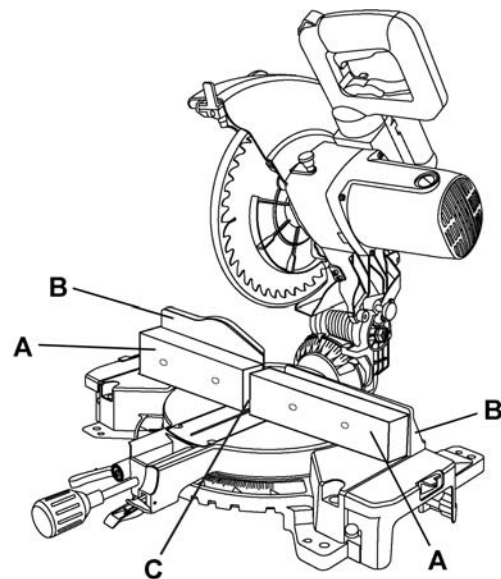

Figure 21

## Cutting Base Molding

Base moldings and many other moldings can be cut on a compound miter saw. The setup of the saw depends on molding characteristics and application, as shown. Perform practice cuts on scrap material to achieve best results:

1. Always make sure moldings rest firmly against fence and table. Use hold-down, crown molding vise or C-clamps, whenever possible, and place tape on the area being clamped to avoid marks.
2. Reduce splintering by taping the cut area prior to making the cut. Mark the cut line directly on the tape.
3. Splintering typically happens due to an incorrect blade application and thinness of the material.

**Note:** Always perform a dry run cut so you can determine if the operation being attempted is possible before power is applied to the saw.

## Crown Molding

Your compound miter saw is suited for the difficult task of cutting crown molding. To fit properly, crown molding must be compound-mitered with extreme accuracy. The two surfaces on a piece of crown molding that fit flat against the ceiling and wall are at angles that, *when added together, equal exactly 90°*.

Most crown molding has a top rear angle (the section that fits flat against the ceiling) of 52° and a bottom rear angle (the section that fits flat against the wall) of 38°.

In order to accurately cut crown molding for a 90° inside or outside corner, lay the molding with its broad back surface flat on the saw table.

When setting the bevel and miter angles for compound miters, remember that the settings are interdependent; changing one changes the other, as well.

## Bevel/Miter Settings

Settings for standard crown molding lying flat on compound miter saw table.

**Note:** The chart below references a compound cut for crown molding *only when the angle between the walls equals 90°*.

Type of Cut	Key	Bevel Setting	Miter Setting	Procedure
Inside corner – Left Side	IL	33.9°	31.6° Right	<ol style="list-style-type: none"> <li>1. Position top of molding against fence.</li> <li>2. Miter table set at RIGHT 31.6°.</li> <li>3. LEFT side is finished piece.</li> </ol>
Inside corner – Right Side	IR	33.9°	31.6° Left	<ol style="list-style-type: none"> <li>1. Position bottom of molding against fence.</li> <li>2. Miter table set at LEFT 31.6°.</li> <li>3. LEFT side is finished piece.</li> </ol>
Outside corner – Left Side	OL	33.9°	31.6° Left	<ol style="list-style-type: none"> <li>1. Position bottom of molding against fence.</li> <li>2. Miter table set at LEFT 31.6°.</li> <li>3. RIGHT side is finished piece.</li> </ol>
Outside corner – Right Side	OR	33.9°	31.6° Right	<ol style="list-style-type: none"> <li>1. Position top of molding against fence.</li> <li>2. Miter table set at RIGHT 31.6°.</li> <li>3. RIGHT side is finished piece</li> </ol>

# Crown Molding Chart

Compound miter saw *miter and bevel angle settings, wall to crown molding angles*

Angle Between Walls	52/38° Crown Molding		45/45° Crown Molding	
	Miter Setting	Bevel Setting	Miter Setting	Bevel Setting
67	42.93	41.08	46.89	36.13
68	42.39	40.79	46.35	35.89
69	41.85	40.50	45.81	35.64
70	41.32	40.20	45.28	35.40
71	40.79	39.90	44.75	35.15
72	40.28	39.61	44.22	34.89
73	39.76	39.30	43.70	34.64
74	39.25	39.00	43.18	35.38
75	38.74	38.69	42.66	34.12
76	38.24	38.39	42.15	33.86
77	37.74	38.08	41.64	33.60
78	37.24	37.76	41.13	33.33
79	36.75	37.45	40.62	33.07
80	36.27	37.13	40.12	32.80
81	35.79	36.81	39.62	32.53
82	35.31	36.49	39.13	32.25
83	34.83	36.17	38.63	31.98
84	34.36	35.85	38.14	31.70
85	33.90	35.52	37.66	31.42
86	33.43	35.19	37.17	31.34
87	32.97	34.86	36.69	30.86
88	32.52	34.53	36.21	30.57
89	32.07	34.20	35.74	30.29
90	31.62	33.86	35.26	30.00
91	31.17	33.53	34.79	29.71
92	30.73	33.19	34.33	29.42
93	30.30	32.86	33.86	29.13
94	29.86	32.51	33.40	28.83
95	29.43	32.17	32.94	28.54
96	29.00	31.82	32.48	28.24
97	28.58	31.48	32.02	27.94
98	28.16	31.13	31.58	27.64
99	27.74	30.78	31.13	27.34
100	27.32	30.43	30.68	27.03
101	26.91	30.08	30.24	26.73
102	26.50	29.73	29.80	26.42
103	26.09	29.38	29.36	26.12
104	25.69	29.02	28.92	25.81
105	25.29	28.67	28.48	25.50
106	24.89	28.31	28.05	25.19
107	24.49	27.96	27.62	24.87
108	24.10	27.59	27.19	24.56
109	23.71	27.23	26.77	24.24
110	23.32	26.87	26.34	23.93
111	22.93	26.51	25.92	23.61
112	22.55	26.15	25.50	23.29
113	22.17	25.78	25.08	22.97
114	21.79	25.42	24.66	22.66
115	21.42	25.05	24.25	22.33
116	21.04	24.68	23.84	22.01
117	20.67	24.31	23.43	21.68
118	20.30	23.94	23.02	21.36
119	19.93	23.57	22.61	21.03
120	19.57	23.20	22.21	20.70
121	19.20	22.83	21.80	20.38
122	18.84	22.46	21.40	20.05
123	18.48	22.09	21.00	19.72

Angle Between Walls	52/38° Crown Molding		45/45° Crown Molding	
	Miter Setting	Bevel Setting	Miter Setting	Bevel Setting
124	18.13	21.71	20.61	19.39
125	17.77	21.34	20.21	19.06
126	17.42	20.96	19.81	18.72
127	17.06	20.59	19.42	18.39
128	16.71	20.21	19.03	18.06
129	16.37	19.83	18.64	17.72
130	16.02	19.45	18.25	17.39
131	15.67	19.07	17.86	17.05
132	15.33	18.69	17.48	16.71
133	14.99	18.31	17.09	16.38
134	14.66	17.93	16.71	16.04
135	14.30	17.55	16.32	15.70
136	13.97	17.17	15.94	15.36
137	13.63	16.79	15.56	15.02
138	13.30	16.40	15.19	14.62
139	12.96	16.02	14.81	14.34
140	12.63	15.64	14.43	14.00
141	12.30	15.25	14.06	13.65
142	11.97	14.87	13.68	13.31
143	11.64	14.48	13.31	12.97
144	11.31	14.09	12.94	12.62
145	10.99	13.71	12.57	12.29
146	10.66	13.32	12.20	11.93
147	10.34	12.93	11.83	11.59
148	10.01	12.54	11.46	11.24
149	9.69	12.16	11.09	10.89
150	9.37	11.77	10.73	10.55
151	9.05	11.38	10.36	10.20
152	8.73	10.99	10.00	9.85
153	8.41	10.60	9.63	9.50
154	8.09	10.21	9.27	9.15
155	7.77	9.82	8.91	8.80
156	7.46	9.43	8.55	8.45
157	7.14	9.04	8.19	8.10
158	6.82	8.65	7.83	7.75
159	6.51	8.26	7.47	7.40
160	6.20	7.86	7.11	7.05
161	5.88	7.47	6.75	6.70
162	5.57	7.08	6.39	6.35
163	5.26	6.69	6.03	6.00
164	4.95	6.30	5.68	5.65
165	4.63	5.90	5.32	5.30
166	4.32	5.51	4.96	4.94
167	4.01	5.12	4.61	4.59
168	3.70	4.72	4.25	4.24
169	3.39	4.33	3.90	3.89
170	3.08	3.94	3.54	3.53
171	2.77	3.54	3.19	3.10
172	2.47	3.15	2.83	2.83
173	2.15	2.75	2.48	2.47
174	1.85	2.36	2.12	2.12
175	1.54	1.97	1.77	1.77
176	1.23	1.58	1.41	1.41
177	0.92	1.18	1.06	1.06
178	0.62	0.79	0.71	0.71
179	0.31	0.39	0.35	0.35

## Maintenance

**⚠WARNING** To avoid injury while performing maintenance, always unplug the power cord before working on the saw. Failure to comply may cause serious injury!

**⚠WARNING** Never use gasoline or any highly volatile solvents to clean the miter saw. Failure to comply may cause serious injury!

**⚠WARNING** Use only replacement parts that are identical to the parts list at the end of this manual and reassemble exactly as the original assembly to avoid electrical shock. Failure to comply may cause serious injury!

### Replacing Carbon Brushes

Replace both carbon brushes when either has less than 1/4 in. length of carbon remaining, or if the spring or wire is damaged or burned.

To inspect or replace brushes:

1. Unplug the saw.
2. Remove the black plastic cap on the side of the motor

Remove the cap cautiously, because it is spring-loaded.

3. Pull out the brush and replace.
4. Reverse above steps to reassemble. Tighten the cap snugly, but do not over-tighten.

Replace the brush for the other side in the same manner described above.

**Note:** To reinstall the same brushes, first make sure the brushes go back in the way they came out. This will avoid a break-in period that reduces motor performance and increases wear.

### Lower Blade Guard

Do not use the saw without the lower blade guard. The lower blade guard is attached to the saw for your protection. Should the lower guard become damaged, do not use the saw until the damaged guard has been replaced. Develop a regular check to make sure the lower guard is working properly. Clean the lower guard of any dust or buildup with a damp cloth.

**⚠WARNING** When cleaning the lower guard, unplug the saw from the power source receptacle to avoid unexpected startup.

**⚠WARNING** Do not use solvents on the guard. They could make the plastic “cloudy” and brittle.

### Saw Dust

Periodically, saw dust will accumulate under the work table and base. This could cause difficulty in the movement of the worktable when setting up a miter cut. Frequently blow out or vacuum up the saw dust.

**⚠WARNING** If blowing saw dust, wear proper eye protection to keep debris from entering eyes.

### Lubrication

All the motor bearings in this tool are lubricated with a sufficient amount of high grade lubricant for the life of the unit under normal operating conditions; therefore, no further lubrication is required.

Lubricate the following as necessary:

Chop pivot: Apply light machine oil to points indicated in illustration.

Central pivot of plastic guard: Use light household oil (sewing machine oil) on metal-to-metal or metal-to-plastic guard contact areas as required for smooth, quiet operation. Avoid excessive oil, to which saw dust will cling.



## Troubleshooting – Motor

Trouble	Probable Cause	Remedy
Brake does not stop blade within 10 seconds.	<ol style="list-style-type: none"> <li>1. Motor brushes not sealed or lightly sticking.</li> <li>2. Motor brake overheated from use of defective or wrong size blade or rapid ON/OFF cycling.</li> <li>3. Arbor bolt loose.</li> <li>4. Brushes cracked, damaged, etc.</li> <li>5. Other.</li> </ol>	<ol style="list-style-type: none"> <li>1. Inspect/clean/replace brushes.</li> <li>2. See MAINTENANCE section.</li> <li>3. Use a recommended blade. Let cool down. See REMOVING OR INSTALLING THE BLADE section.</li> <li>4. Retighten. See REMOVING OR INSTALLING THE BLADE section.</li> <li>5. Replace brushes. Contact your Service Center.</li> </ol>
Motor does not start	<ol style="list-style-type: none"> <li>1. Limit switch failure</li> <li>2. Brush worn.</li> <li>3. Fuse blown or circuit breaker tripped on home panel.</li> </ol>	<ol style="list-style-type: none"> <li>1. Replace limit switch.</li> <li>2. Replace brushes. See Maintenance section.</li> <li>3. Verify there is electrical power at the outlet.</li> </ol>
Brush spark when switch released.	<ol style="list-style-type: none"> <li>1. Worn brush.</li> <li>2. Other.</li> </ol>	<ol style="list-style-type: none"> <li>1. Replace brushes. See Maintenance section.</li> <li>2. Contact your Service Center.</li> </ol>

## Troubleshooting – Operation

Trouble	Probable Cause	Remedy
Blade hits table.	<ol style="list-style-type: none"> <li>1. Misalignment.</li> </ol>	<ol style="list-style-type: none"> <li>1. See the Setting Cutting Depth section in Adjustments</li> </ol>
Angle of cut not accurate. Can not adjust miter.	<ol style="list-style-type: none"> <li>1. Miter table unlocked.</li> <li>2. Saw dust under table.</li> </ol>	<ol style="list-style-type: none"> <li>1. See the Miter Angle Adjustment section in Operations</li> <li>2. Vacuum or blow out dust. Important: Wear eye protection.</li> </ol>
Cutting arm wobbles.	<ol style="list-style-type: none"> <li>1. Loose pivot points.</li> </ol>	<ol style="list-style-type: none"> <li>1. Contact Service Center.</li> </ol>
Cutting arm will not fully raise, or blade guard won't fully close.	<ol style="list-style-type: none"> <li>1. Pivot spring not replaced properly after service.</li> <li>2. Saw dust build-up.</li> </ol>	<ol style="list-style-type: none"> <li>1. Contact Service Center.</li> <li>2. Clean and lubricate moving parts.</li> </ol>
Blade binds, jams, burns wood.	<ol style="list-style-type: none"> <li>1. Improper operation.</li> <li>2. Dull or warped blade.</li> <li>3. Improper blade size.</li> <li>4. Wood is moving during cut.</li> </ol>	<ol style="list-style-type: none"> <li>1. See Operations section.</li> <li>2. Replace or sharpen blade.</li> <li>3. Replace with 10 in. diameter blade.</li> <li>4. Use hold down clamp to secure workpiece to table.</li> </ol>
Saw vibrates or shakes.	<ol style="list-style-type: none"> <li>1. Saw blade not round / damaged / loose.</li> <li>2. Arbor bolt loose.</li> </ol>	<ol style="list-style-type: none"> <li>1. Replace blade.</li> <li>2. Tighten arbor bolt.</li> </ol>
Laser not aligned	--	<ol style="list-style-type: none"> <li>1. Contact Service Center.</li> </ol>
Laser turns off	<ol style="list-style-type: none"> <li>1. Laser turns off after 20 minutes to prevent heat buildup.</li> </ol>	<ol style="list-style-type: none"> <li>1. Reset laser switch on trigger handle (turn off for two seconds, then on again).</li> </ol>

# Parts

## Ordering Replacement Parts

To order parts or reach our service department, call 1-800-274-6848 between 7:30am and 5:30pm (CST), Monday through Friday. Having the Model Number and Serial Number of your machine available when you call will allow us to serve you quickly and accurately.

## Parts List

**Note:** Parts without part numbers are for reference only and cannot be purchased individually.

Index No.	Part No.	Description	Size	Qty
1	JMS10CMS-1	Lower Handle		1
2	JMS10SCMS-10	Cord Clamp		1
3	JMS10CMS-3	Compression Spring		1
4	JMS10CMS-4	Spring Wire		1
5	JMS10CMS-5	Handle Segment		1
6	JMS10SCMS-19	Blade Wrench		1
7	JMS10CMS-7	Pan Head Tapping Screw	M4-18x16	2
8	JMS10SCMS-88	Terminal		2
9	JMS10CMS-9	Pan Head Tapping Screw	M6-1x25	2
10	JMS10SCMS-69	Pan Head Tapping Screw	M4-18x25	4
11	JMS10SCMS-65	Pan Head Tapping Screw	M3-24x10	1
12	JMS10CMS-12	Limit Switch		1
13	JMS10CMS-13	Cord Guard		1
14	JMS10SCMS-170	Rocker Switch		1
15	JMS10CMS-15	Lead Wire		1
16	TS-1533062	Pan Head Screw	M5x20	1
17	JMS10CMS-17	Upper Handle		1
18	JMS10CMS-18	Trigger		1
19	JMS10CMS-19	Green Laser Controller Assembly		1
20	JMS10CMS-20	Pan Head Screw with Washer	M6x45	2
21	JMS10CMS-21	Motor		1
22	JMS10CMS-22	Motor Brush Cover		2
23	JMS10CMS-23	Motor Brush		2
24	TS-2342161	Nylon Insert Lock Nut	M16	1
25	TS-1541041	Nylon Insert Lock Nut	M10	1
26	TS-155010	Flat Washer	M16	2
27	TS-0680041	Flat Washer	3/8	1
28	JMS10CMS-28	Special Bolt		1
29	JMS10CMS-29	Pivot Shaft		1
30	TS-2171012	Pan Head Screw	M4x6	2
31	JMS10CMS-31	Pin		1
32	JMS10CMS-32	Table		1
33	JMS10CMS-33	Shaft		1
34	JMS10CMS-34	O-Ring		1
35	JMS10CMS-35	Pointer		1
36	JMS10SCMS-14	Knob		1
37	TS-2342121	Nylon Insert Lock Nut	M12	1
38	TS-0680061	Flat Washer	1/2	1
39	JMS10CMS-39	Pointer, Right		1
40	JMS10CMS-40	Disc		1
41	JMS10CMS-41	Pan Head Tapping Screw	M5-16x10	1
42	TS-2360121	Flat Washer	M12	1
43	JMS10SCMS-104	Bushing		1
44	TS-1502051	Socket Head Cap Screw	M5x20	1
45	JMS10CMS-45	Locking Rod		1
46	TS-1540041	Hex Nut	M6	2

## Parts List

Index No.	Part No.	Description	Size	Qty
47	TS-1541031	Nylon Insert Lock Nut	M8	1
48	TS-1550061	Flat Washer	M8	1
49	TS-1533032	Pan Head Screw	M5x10	1
50	JMS10CMS-50	Pointer		1
51	JMS12SCMS-188	Handle		1
52	TS-1482041	Hex Cap Screw	M6x20	2
53	JMS10SCMS-33	Flat Washer	1/4x1/2x3/32	1
54	TS-2361061	Lock Washer	M6	1
55	TS-1503041	Socket Head Cap Screw	M6x16	1
56	JMS10CMS-56	Pin		1
57	JMS10CMS-57	Screw Stop		1
58	JMS10SCMS-8	Nut		1
59	JMS10SCMS-41	E-Clip	E-6	1
60	JMS10CMS-60	Miter Lock Handle Assembly		1
61		Miter Lock Handle		1
62		Link		1
63		Shaft		1
64		Spring Pin	Ø2.5x8	2
65	JMS10CMS-65	Compression Spring		1
66	TS-1541011	Nylon Insert Lock Nut	M5	1
67	JMS10CMS-67	Follower Plate		1
68	JMS10CMS-68	Hex Cap Screw with Flat & Lock Washers	M6x16	1
69	JMS10CMS-69	Compression Spring		1
70	TS-1523061	Socket Set Screw	M6x20	1
71	TS-1502081	Socket Head Cap Screw	M5x35	1
72	TS-1550021	Flat Washer	M4	1
73	JMS10CMS-73	Table Insert		1
74	TS-2284082	Pan Head Screw	M4x8	4
75	JMS10CMS-75	Bevel Arm		1
76	JMS10CMS-76	Locking Handle Assembly		1
77	JMS10CMS-77	Release/Stop Lever		1
78	JMS10SCMS-37	Wave Washer	WW-8	2
79	TS-1533042	Pan Head Screw	M5x12	2
80	TS-1541011	Nylon Insert Lock Nut	M5	2
81	JMS10CMS-81	Extension Rod		2
82	JMS10CMS-82	Pan Head Screw	M5x6	2
83	JMS10CMS-83	Stop Plate, Left		1
84	JMS10CMS-84	Extension Wing, Left		1
85	JMS10CMS-85	Extension Rod		2
86	JMS10SCMS-61	Round Washer Head Screw	M5x12	4
87	JMS10CMS-87	Fence Extension		1
88	JMS10CMS-88	Fence		1
89	JMS10SCMS-56	Socket Head Cap Screw with Washer	M8x25	1
90	JMS10CMS-90	Socket Head Cap Screw with Washer	M8x30	2
91	JMS10SCMS-17	Center Bolt		1
92	JMS10SCMS-95	Knob		2
93	JMS10CMS-93	Slide Plate		3
94	JMS12SCMS-118	Knob		2
95	JMS10CMS-95	Locking Handle Assembly		1
96		Cushion		1
97		Lock Handle		1
98		Pin	Ø5x16	1
99		Lock Screw		1
100		Plate		1
101		Flat Washer	M6	1
102		Nylon Insert Lock Nut	M6	1
103	JMS10CMS-103	Extension Wing, Right		1

## Parts List

Index No.	Part No.	Description	Size	Qty
104	JMS10CMS-104	Stop Plate, Right		1
105	JMS10CMS-105	Base		1
106	JMS10SCMS-54	Arbor Bolt		1
107	JMS10CMS-107	Torsion Spring		1
108	JMS10SCMS-64	Truss Head Round Neck Screw	M6x14	1
109	JMS10SCMS-16	Guard Spring		1
110	TS-1541021	Nylon Insert Lock Nut	M6	1
111	JMS10SCMS-64	Truss Head Round Neck Screw	M6x14	1
112	JMS10CMS-112	Guard Plate		1
113	JMS10CMS-113	Pan Head Round Neck Screw	M6x12	1
114	JMS10CMS-114	Blade Guard		1
115	TS-1541021	Nylon Insert Lock Nut	M6	1
116	JMS10CMS-116	Saw Arm		1
117	JMS10CMS-117	Green Laser		1
118	JMS10SCMS-1	Shaft Sleeve		1
119	JMS10CMS-119	Lever		1
120	TS-1503041	Socket Head Cap Screw	M6x16	2
121	JMS10CMS-121	Shim		1
122	TS-1503041	Socket Head Cap Screw	M6x16	1
123	JMS10CMS-123	Anchor Block		1
124	JMS10CMS-124	Truss Head Screw	M6x8	1
125	JMS10SCMS-15	Collar		1
126	TS-1534051	Flat Head Screw	M6x16	1
127	TS-1541021	Nylon Insert Lock Nut	M6	1
128	JMS10CMS-128	Rubber Sleeve		1
129	JMS10CMS-129	Arbor Collar		2
130	TS-1550041	Flat Washer	M6	1
131	JMS10CMS-131	SHCS with Plastic Lock Washer	M5x35	3
132	JMS10CMS-132	Truss Head Screw	M4x8	3
133	JMS10CMS-133	Cover		2
134	TS-1523031	Socket Set Screw	M6x10	2
135	JMS10SCMS-162	Slotted Set Screw	M6x8	6
136	JMS10CMS-136	Link Bracket		1
137	JMS10CMS-132	Truss Head Screw	M4x8	3
138	JMS10CMS-138	Cable Shield		1
139	JMS10SCMS-37	Wave Washer	WW-8	1
140	JMS10CMS-140	Laser Housing		1
141	TS-1541021	Nylon Insert Lock Nut	M6	1
142	JMS10CMS-142	Anchor Block		1
143	TS-1503031	Socket Head Cap Screw	M6x12	1
144	JMS10CMS-144	Clamp Hold Down Assembly		1
145		Flange Pad		1
146		Clamp Hold Down Arm		1
147		Flat Washer	M10	1
148		Flat Washer	3/16	1
149		Pan Head Screw with Lock Washer	M5x10	1
150		Support Post		1
151		Lock Knob		1
152		Clamp Spindle & Knob Assembly		1
153	JMS10SCMS-90	Dust Bag		1
154	JMS10CMS-154	Power Cord		1
155	JMS10SCMS-192	Saw Blade	10"x40Tx5/8" Arbor	1
156	JMS10SCMS-11	Warning Label		1
157	JMS10CMS-157	Label: Miter Quick Lock		1
158	JMS10SCMS-103	Warning Label: Avoid Exposure		1
159	JMS10CMS-159	Bevel Angle Scale		1
160	JMS10CMS-160	Miter Angle Scale		1

## Parts List

Index No.	Part No.	Description	Size	Qty
161	JMS10CMS-161	ID Label		1
162	JMS10CMS-162	Label: Laser On/Off		1
163	JMS10CMS-163	JET Label for Handle		1
164	JMS10SCMS-202	JET Label		1
165	JMS10SCMS-198	Label: Laser Caution		1
166	JMS10SCMS-172	Label: Do Not Remove		1
167	JMS10CMS-167	Label: Bevel Lock		1
168	JMS10CMS-168	Label: Rotation		1

# Assembly Drawing

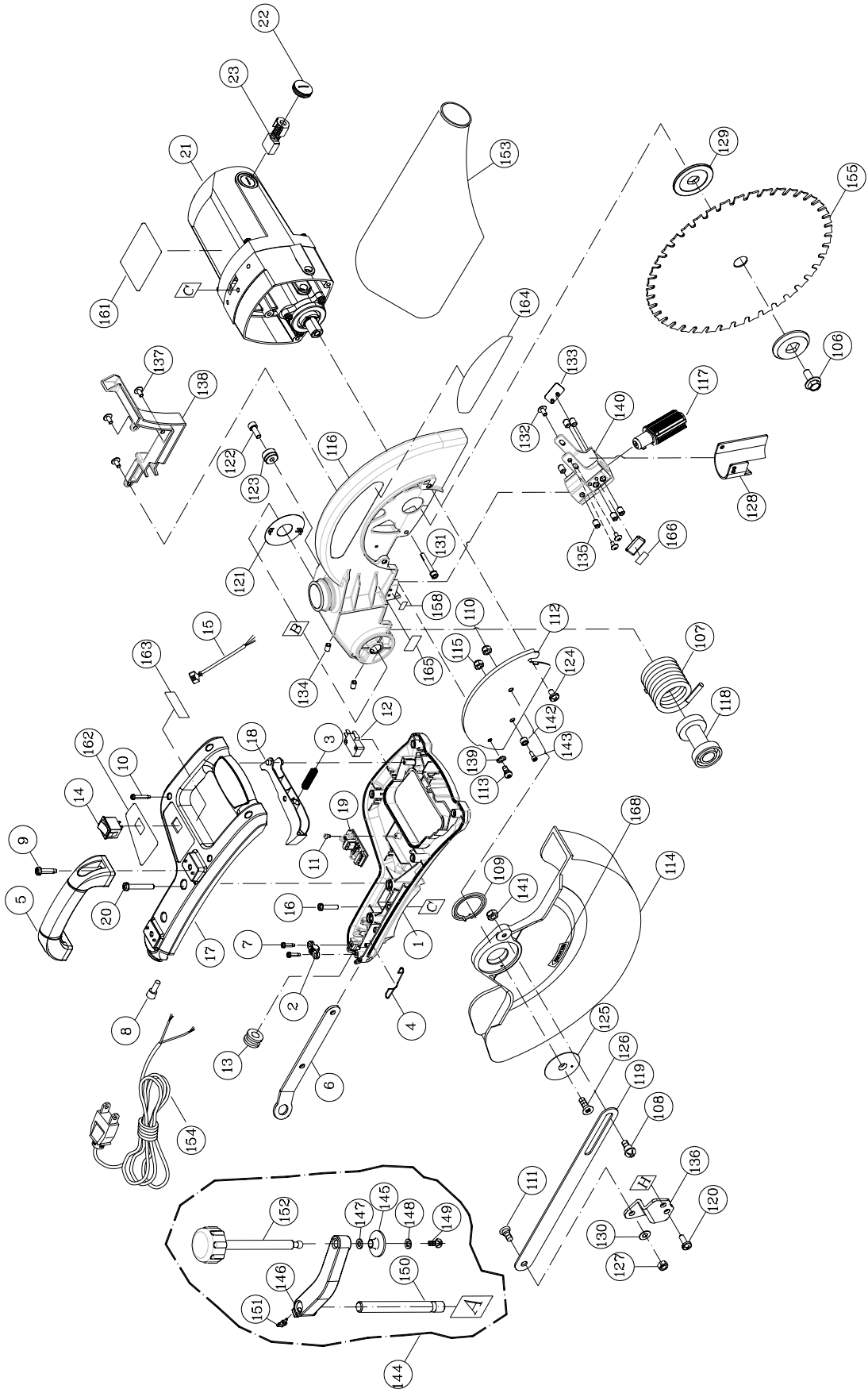

Assembly Drawing (continued)

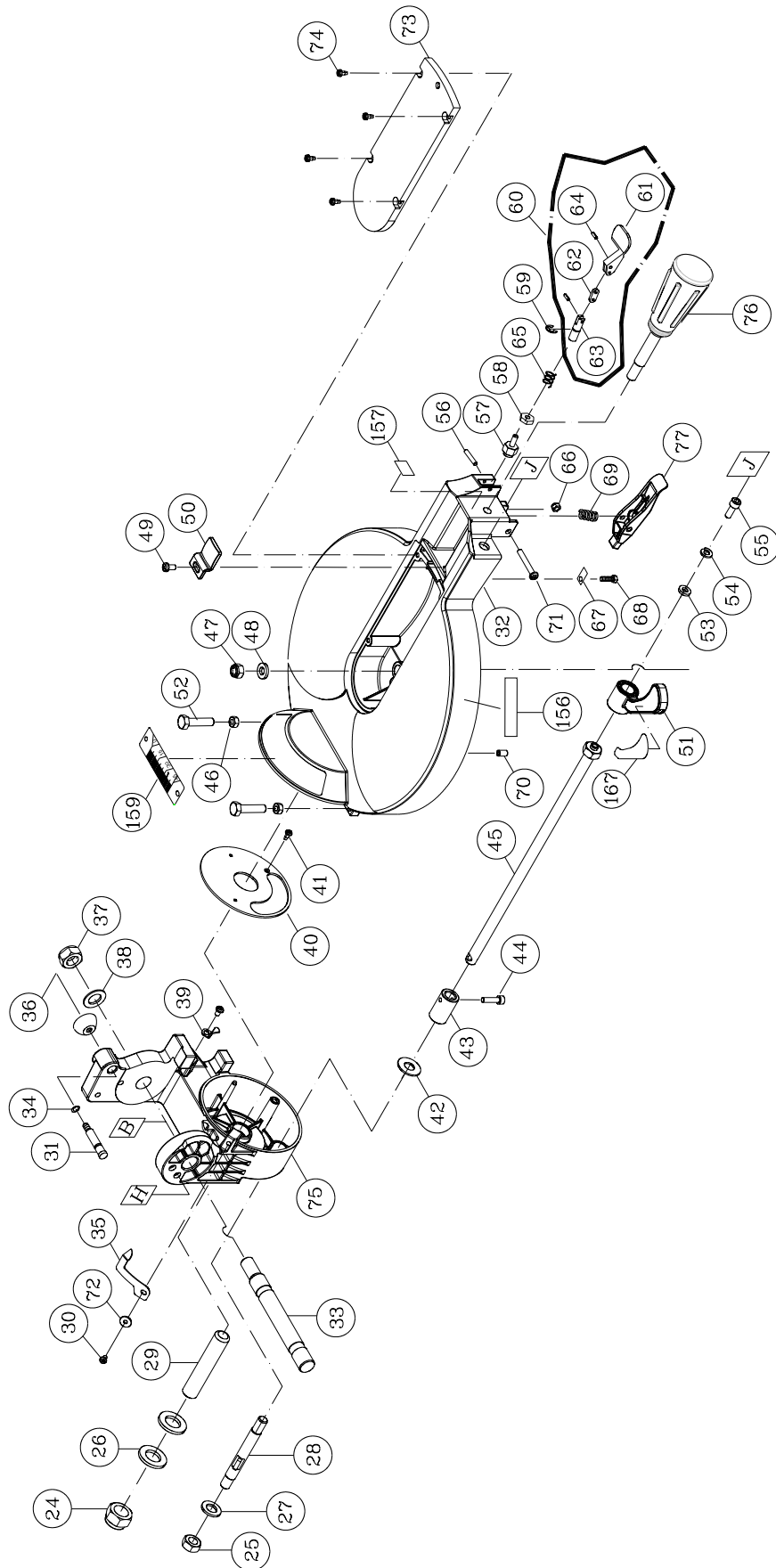

Assembly Drawing (continued)

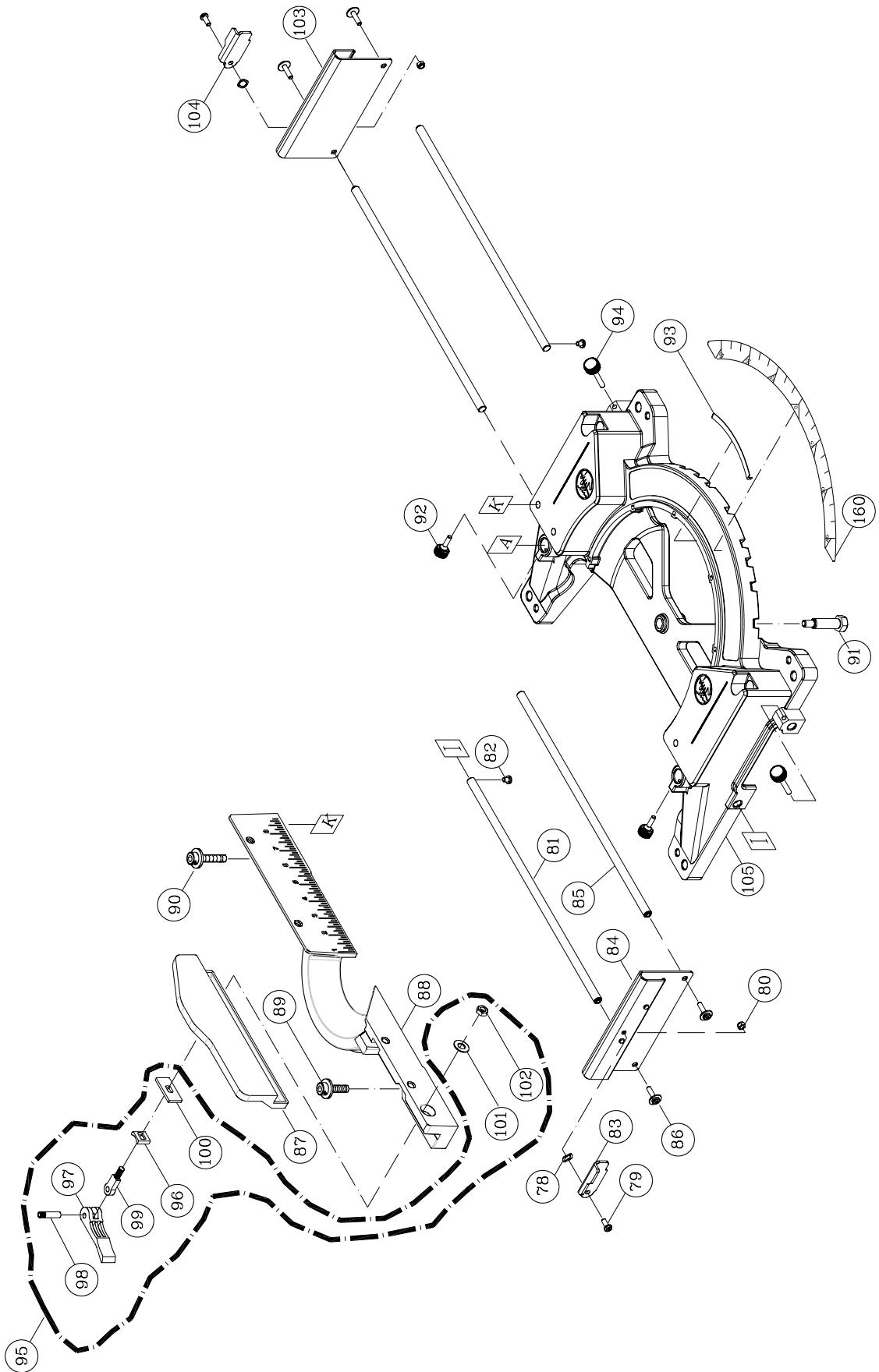



# Wiring Diagram

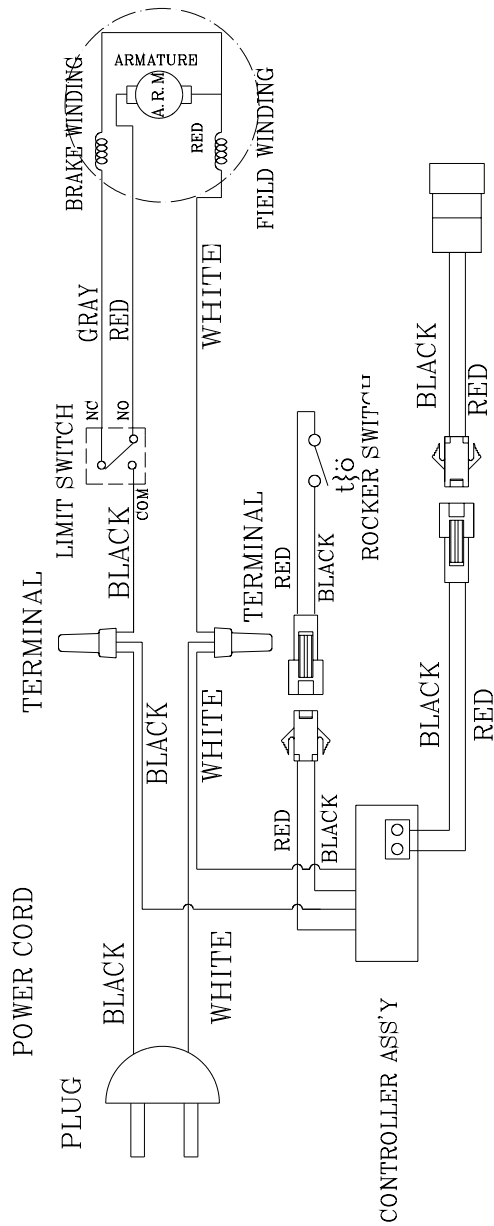

GREEN LASER ASS'Y

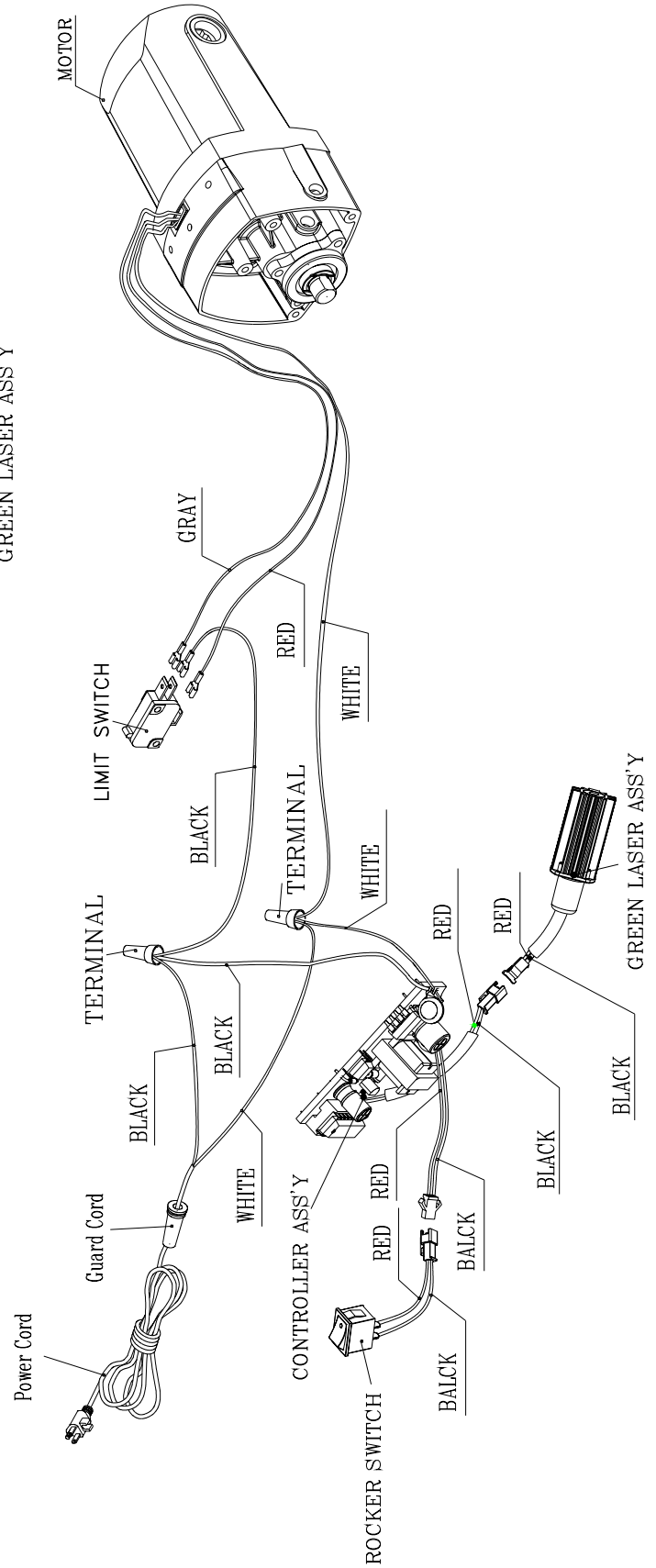

# Notes

# Notes



**WMH Tool Group, Inc.**  
2420 Vantage Drive  
Elgin, Illinois 60124  
Phone: 800-274-6848  
[www.wmhtoolgroup.com](http://www.wmhtoolgroup.com)